



—
linea mini
quick start
guide

—
WWW.LAMARZOCCO.COM

VIA LA TORRE 14/H
50038 SCARPERIA E SAN PIERO
FLORENCE - ITALY



la marzocco
HOME

linea mini overview

This Quick Start Guide is an overview of the basic steps for using your Linea Mini, for a more in depth discussion of these topics, see the manual.

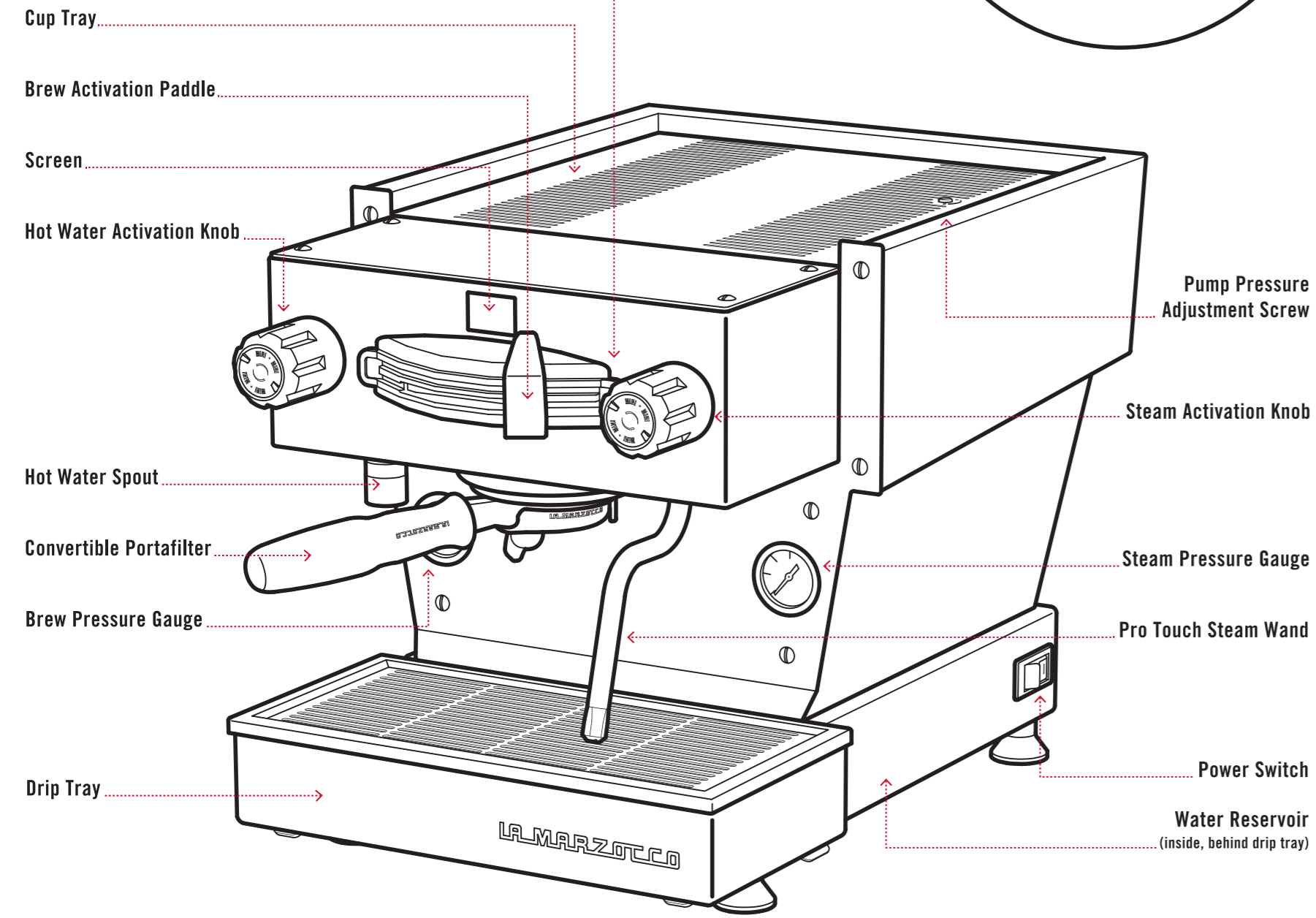

view complete instructions online at www.lamarzocco.com

unpacking & set up

You will need two people to lift the machine, it is over 70 lbs (30 kg). During setup refer to the manual for more detailed information.

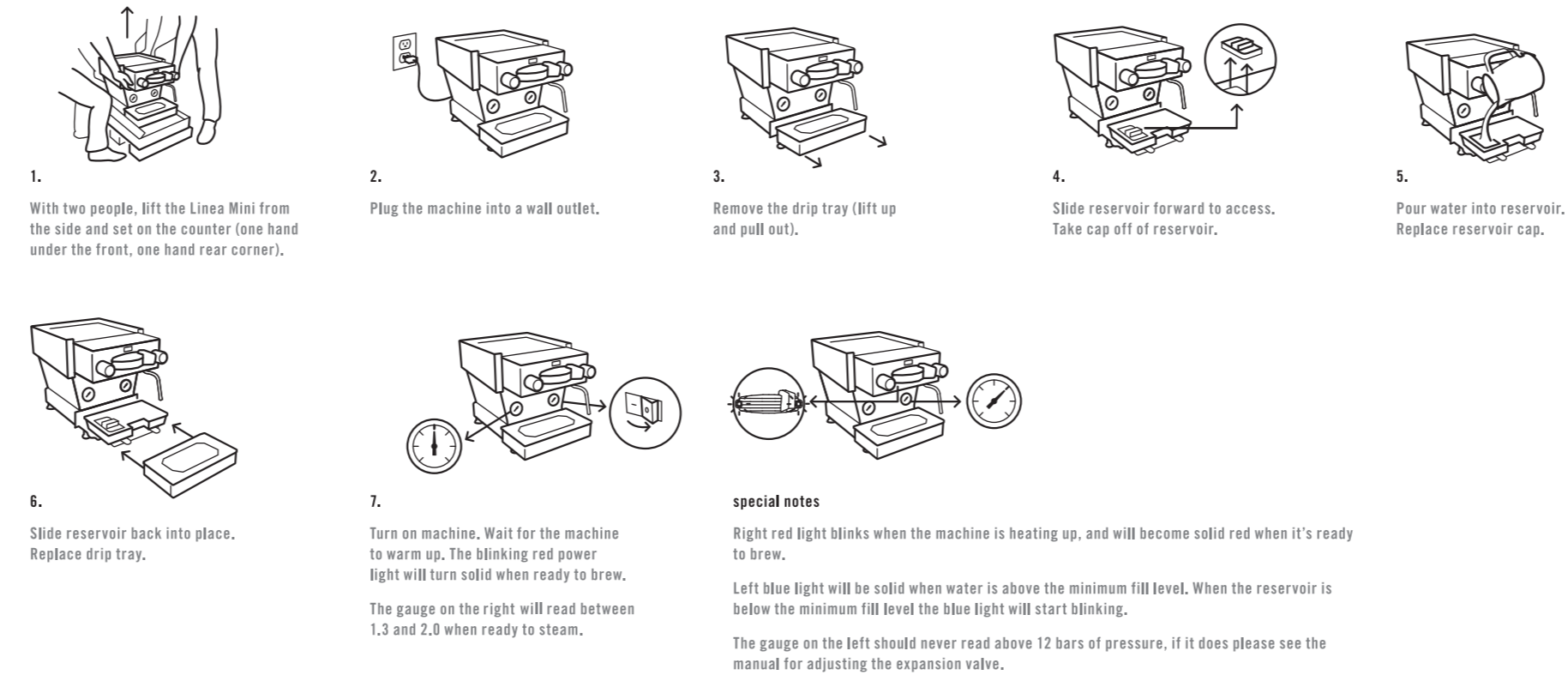

making coffee

You will need whole bean coffee, grinder, tamper, knock box and a scale (optional, but recommended)

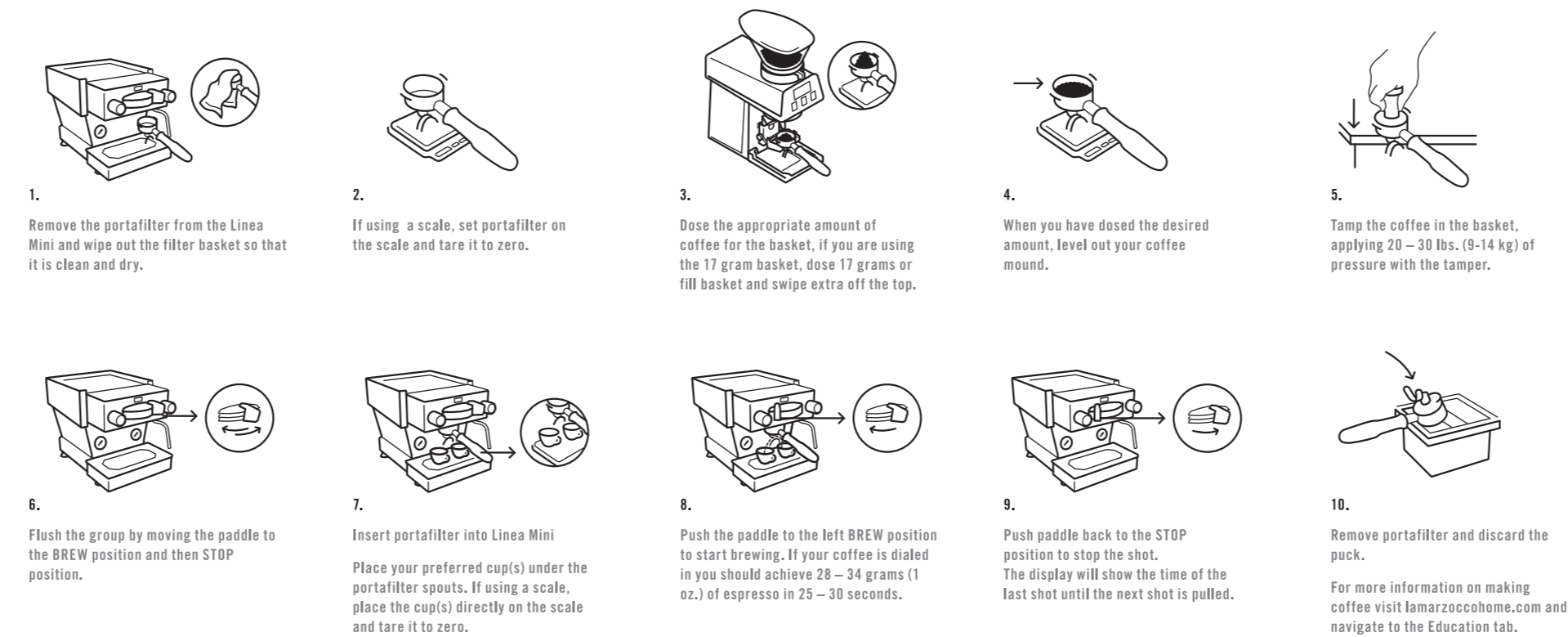

steaming milk

You will need a steaming pitcher and cold milk

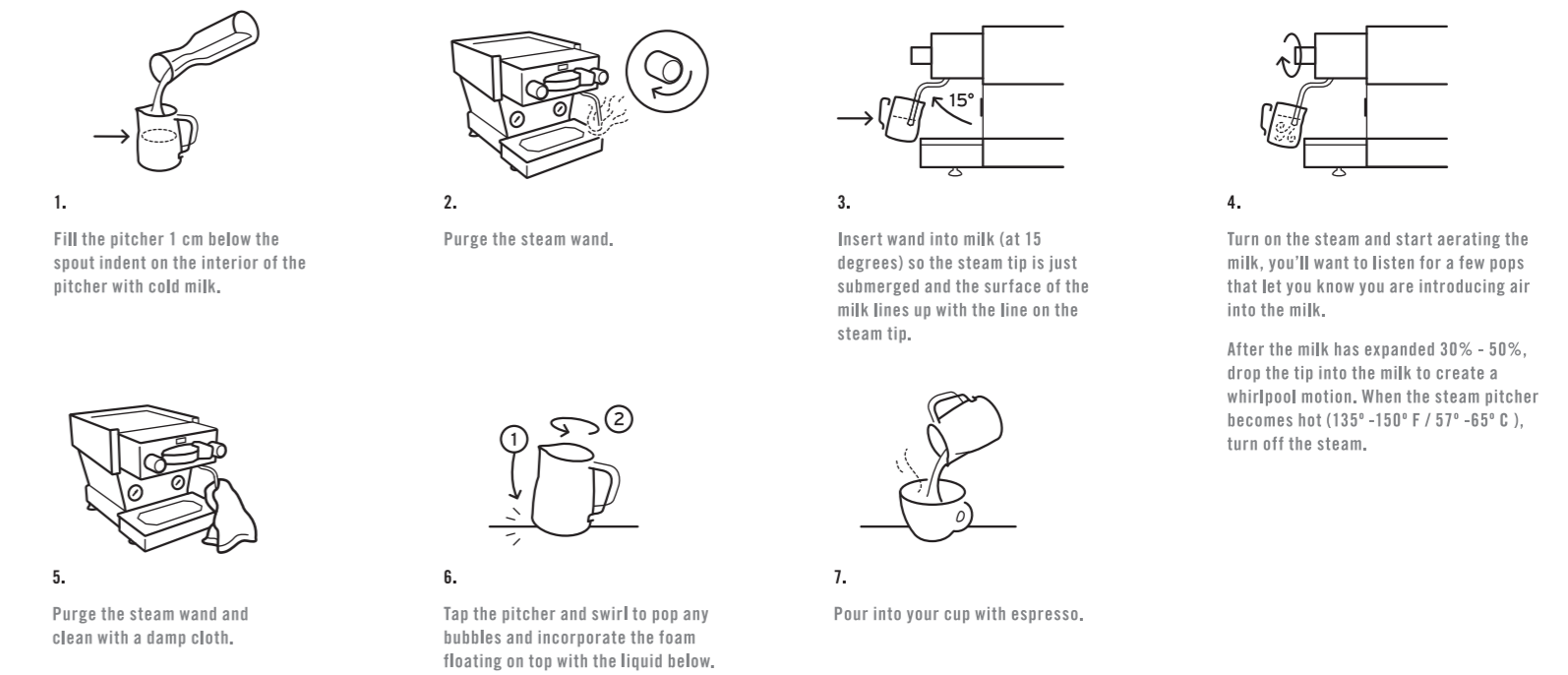

maintenance

You will need a short flat head screwdriver, medium sized bowl, hot water, Puro cleaning solution, spoon

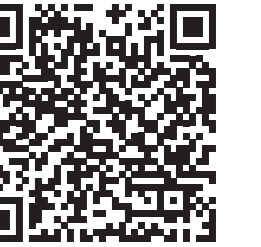
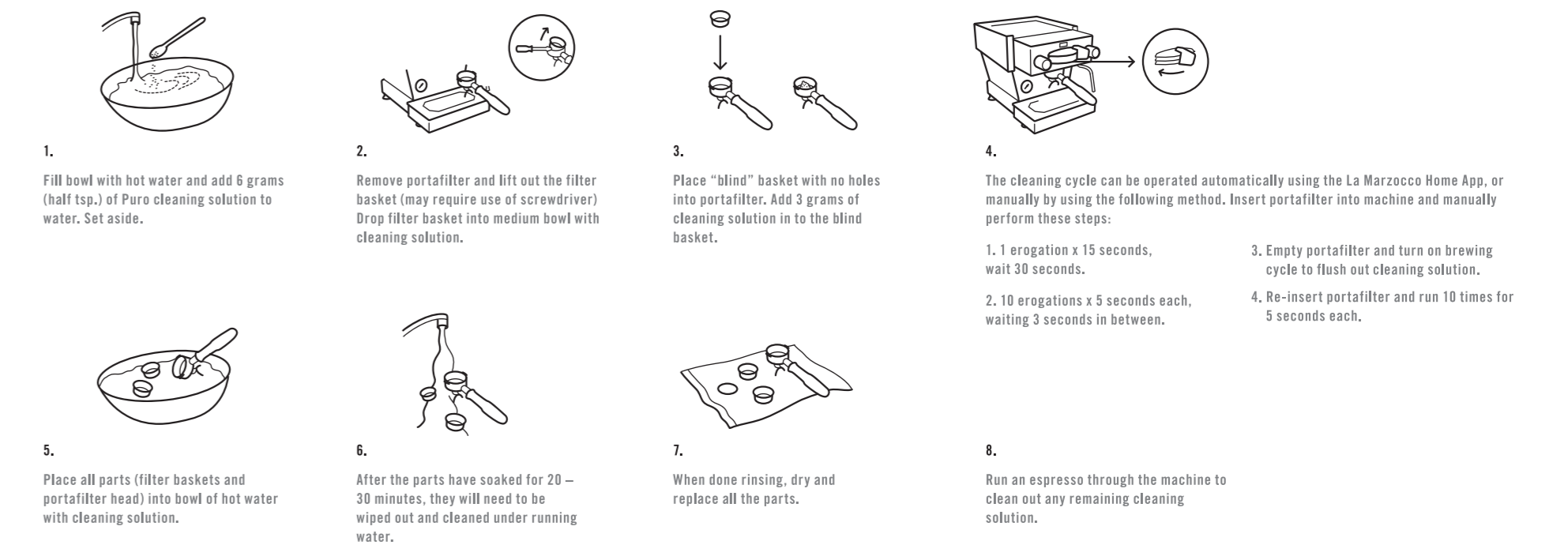

for more information scan this QR code